

---

# Commodore Single Disk Drive

---

## Technical Manual

---

Model 1540/1541

---



 **commodore**  
COMPUTER

These documents are for repair service information only. Part numbers are for reference only. Only parts on current dealer parts list are available. No license is given for any use by possession of these documents and may not be reproduced in any form without the written approval of Commodore Electronics Limited.

## CONTENTS

### Chapter 1

- 1.1 Scope
- 1.2 Unpacking
- 1.3 Protection against noise
- 1.4 Input-Output cable
- 1.5 DC power source
- 1.6 Initial inspection
- 1.7 Outline of functions
- 1.8 Read/Write Head
- 1.9 Track positioning mechanism
- 1.10 Spindle drive mechanism
- 1.11 Eject mechanism

### Chapter 2

- 2.1 Mechanism explanation
- 2.2 Functional explanation
- 2.3 Assembly procedure

### Chapter 3

- 3.1 Operating procedure
- 3.2 Media handling procedure
- 3.3 Seek error
- 3.4 Write error
- 3.5 Read error
- 3.6 Head cleaning
- 3.7 Adjustment procedure

## Chapter One

### 1.1 Scope

In this chapter, a description is made of the procedures necessary for servicing the Model 1540/1541 Floppy Disk Drive.

### 1.2 Unpacking

Special care should be exercised during unpacking not to damage the unit.

Unpacking procedures are as follows:

- a) Remove cardboard sleeve from styro-foam box
- b) Open 'styro-foam' box and remove drive
- c) Check the drives front door for proper operation

```
*****  
*                                     *  
*           Caution                 *  
*                                     *  
*   Do Not Use Magnetized Tools   *  
*                                     *  
*****
```

### 1.3 Protection against noise

A weak signal from the media is detected in the head section of the drive. Hence, **do not** install the drive near a TV set or other areas where electromagnetic noise is generated. (i.e. motors, air-conditioners, etc)

### 1.7 Input/Output Cable

The length of the cable between the host and the drive (between the host and the last drive when the drives are daisy chained) should not exceed 5 meters (16 feet).

### 1.8 DC power source

The drive is powered by a internal power supply providing the drive with +12V and +5V.

### 1.9 Initial inspection

The drive can be briefly inspected for its operation by the following procedure. Install the drive, connect the power and I/O cables. Turn drive on and make sure the front panel power lamp is on. Proceed to step 2.2.

#### 1.10 Outline of functions

The 1540/1541 Minifloppy Disk Drive mechanism is composed of the data read/write head, track positioning mechanism, spindle drive mechanism and eject mechanism.

#### 1.11 Read/Write Head

The Read/Write head uses a glass-bonded, ferrite/ceramic head. Track-to-track erasing is accomplished by the straddle erase method. The surface of the Read/Write head is mirror-ground to minimize wear of the head and media. Also, the head is designed in such a way that the maximum signal can be obtained from the media surface.

#### 1.12 Track positioning mechanism

Positioning of the Read/Write Head is accomplished by a stepping motor and steel belt. The stepping motor rotates clockwise or counter-clockwise by two steps per track. The control circuit on the logic board selects the direction and number of step to the desired track.

#### 1.13 Spindle drive mechanism

The spindle drive motor operates on 12 VDC and turns the spindle, through a belt drive, at 300 revolutions per minute. The speed of the drive motor is controlled by a feedback signal from a tachometer which is housed in the drive motor assembly. The feedback signal controls a servo amp that supplies the 12 VDC drive current.

#### 1.14 Eject mechanism

When the media is inserted in the Disk Drive and the door is closed the media is clamped by the spindle and hub. At this time the ejector mechanism is loaded by the insertion of the disk and locked. When the door is opened, the ejector mechanism is unlocked and the media pops out of the door.

## Chapter Two

### 2.1 Mechanism Explanation

The 1540/1541 mechanism is installed in the system horizontally, however the drive will function if mounted vertically. The mechanical parts of the drive include an aluminum chassis, a stepping motor, head positioning assembly, drive motor, a hub and spindle assembly for centering and retaining the media during operation. The magnetic head is of a glass ceramic construction.

### 2.2 Function explanation

The drive is itself an independent memory device. The drive is composed of a media clamp rotating mechanism, ahead positioning mechanism and an eject mechanism. When the front door opens, the media can be inserted. All positioning operation excluding insertion and removal of the media are controlled by the internal guide mechanism. Closing the front door causes the media clamp mechanism to operate. Two operations are performed in the following order:

- a) The media is centered.
- b) The media is clamped and retained between the spindle and the hub.

The spindle and hub rotate at 300 r.p.m. through a closed-loop control circuit employing a D.C. motor/tachometer. It is important that the relationship between the head and the media is maintained correctly during operation. For this purpose, a pressure pad is used to hold and press down the media (about 12g) from the opposite side of the head, to maintain the correct contact with the head. This head assembly is coupled by a metal band to a four phase stepping motor the performs the track positioning. One step of the stepping motor corresponds to a 1/2 track movement. Use of a high-speed stepping motor and metal band drive, this series of disk drives can perform access operations at a very high speed.

### 2.3 Assembly Procedure

- 2.3.1 The housing assembly; install the eject pin and the spindle.
- 2.3.2 The housing assembly; on the reverse side install the spindle pulley.

2.3.3 FIG 1, The housing unit.

Part	Description
22	spindle
33	housing assembly.
53	eject pin

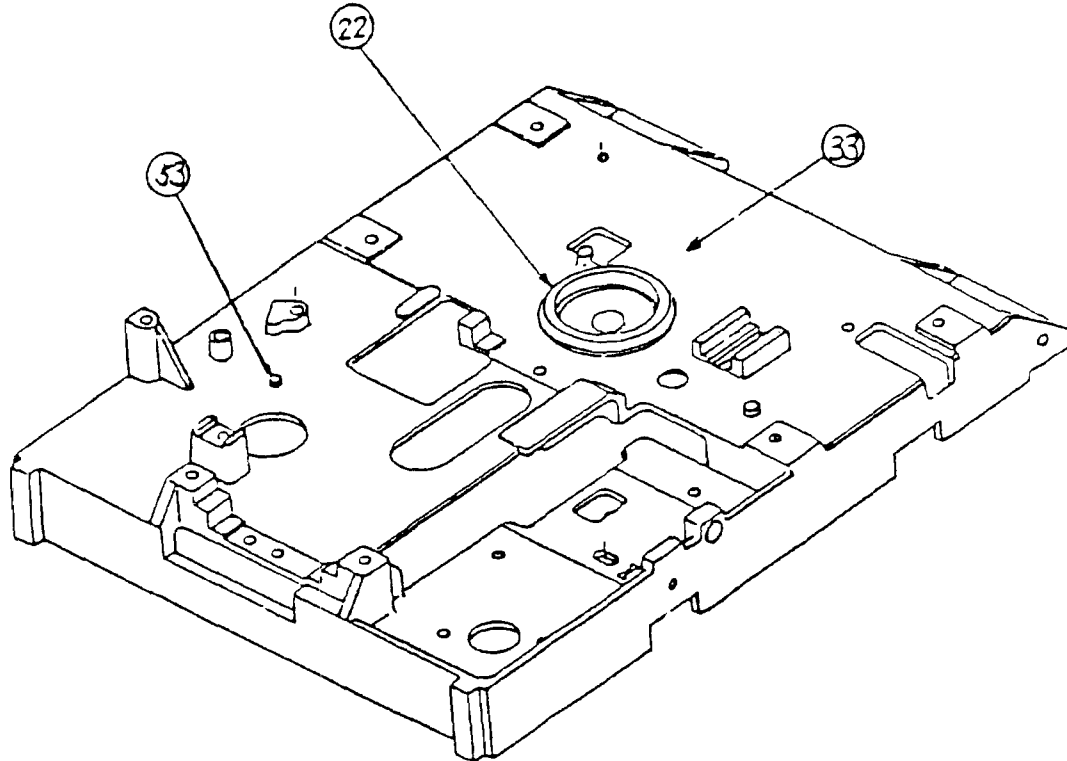

2.3.4 The stepping motor assembly; install the stepping pulley.

2.3.5 FIG 2, The stepping motor unit

Part	Description
50	stepping motor assembly
55	connector housing
58	stepper pulley

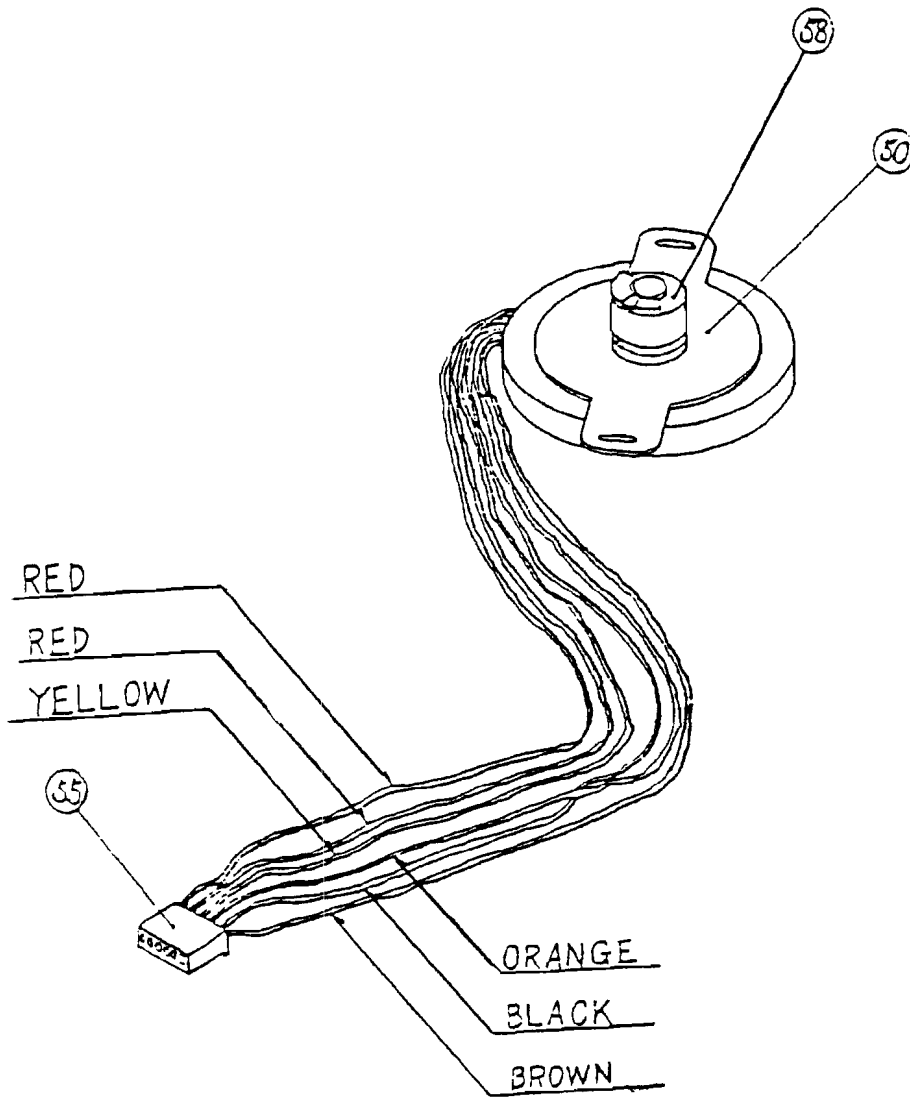

2.3.6 The D.C. motor assembly; install the motor pulley.

2.3.7 FIG 3, D.C. motor and control PCB

Part	Description
44	motor control PCB
48	D.C. motor
51	connector housing
59	D.C. motor pulley

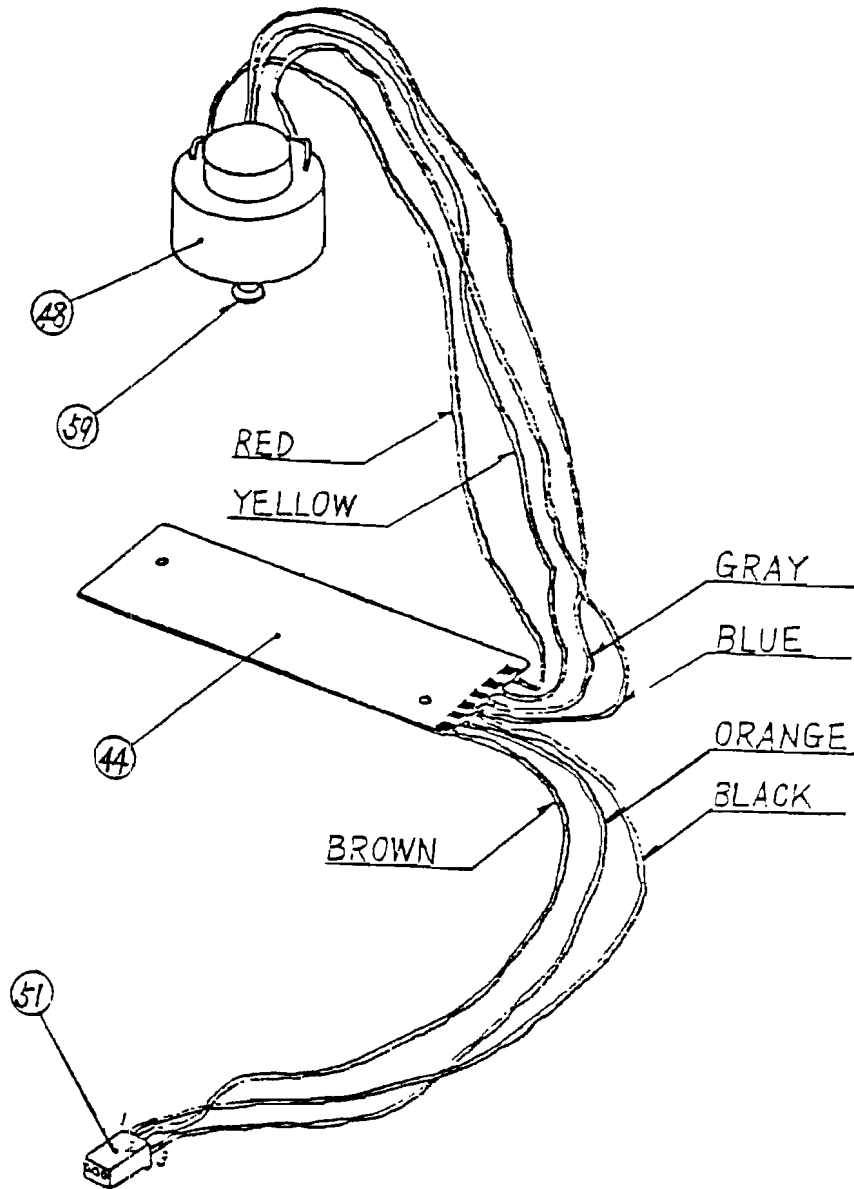

FIG. 6

Part	Description	Part	Description
20	binder screw	37	washer
21	diskette guide	38	eject spring
28	LED clamp	39	eject plate
29	front panel	40	slider
30	Flush screw	43	diskette guide
31	LED assembly	52	connector housing
32	LED holder ring		

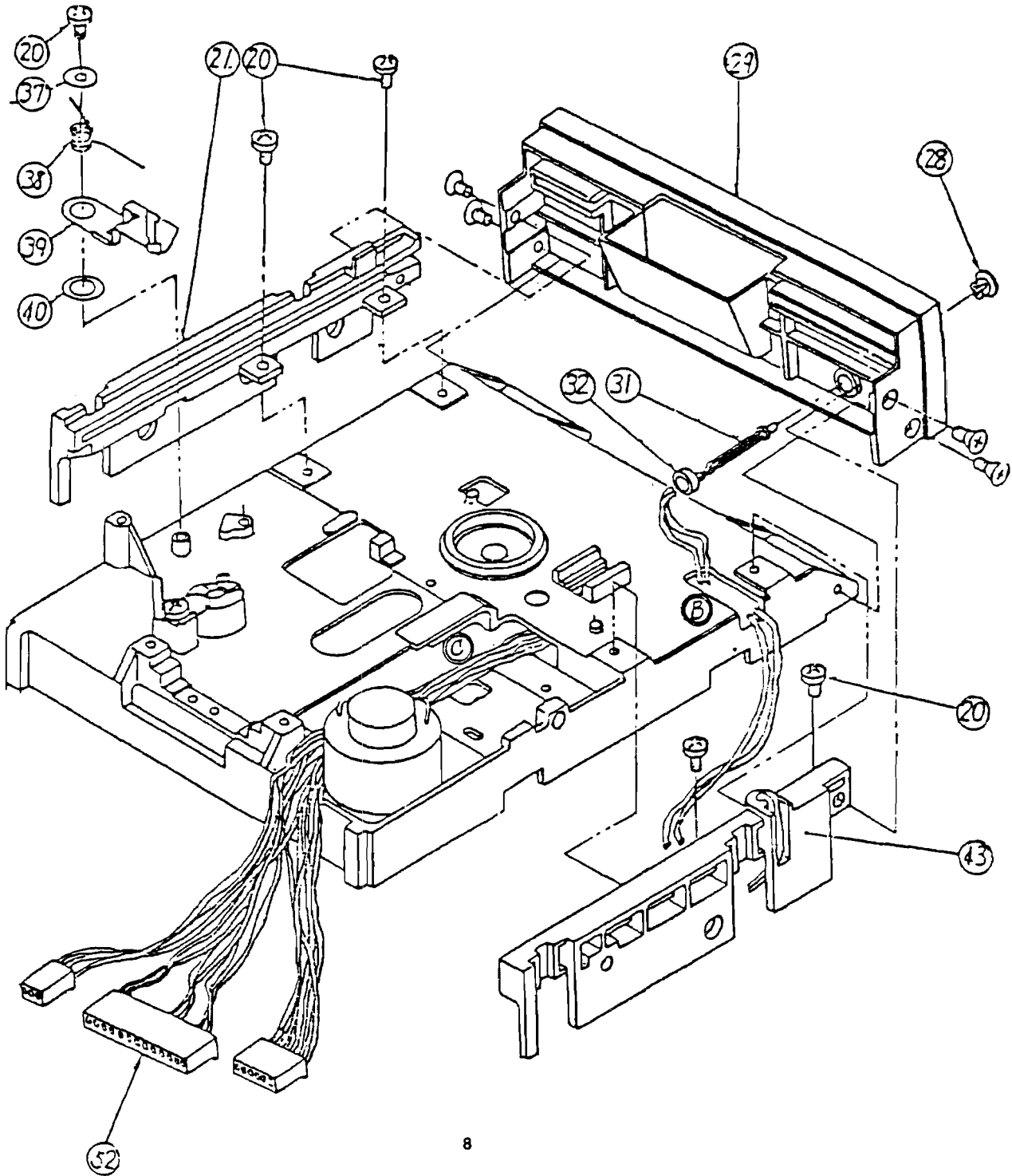

FIG 7.

Part	Description
15	binder screw
18	binder screw
24	tension pulley
25	guide shaft keeper
26	guide shaft
34	metal band
35	washer
36	head assembly
56	tension spring

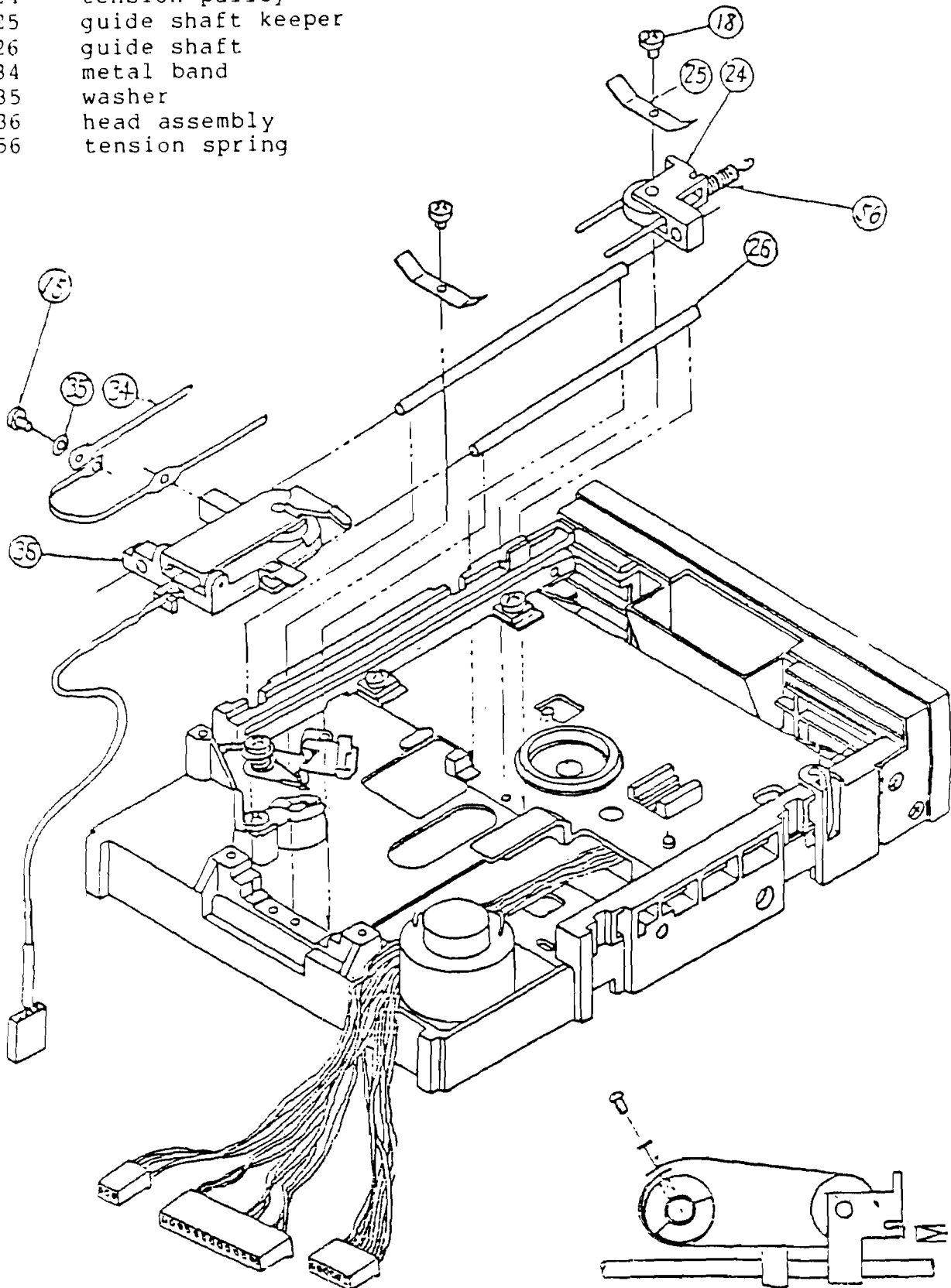

FIG 8

Part	Description
20	binder screw
45	cable clamp
49	cable ties

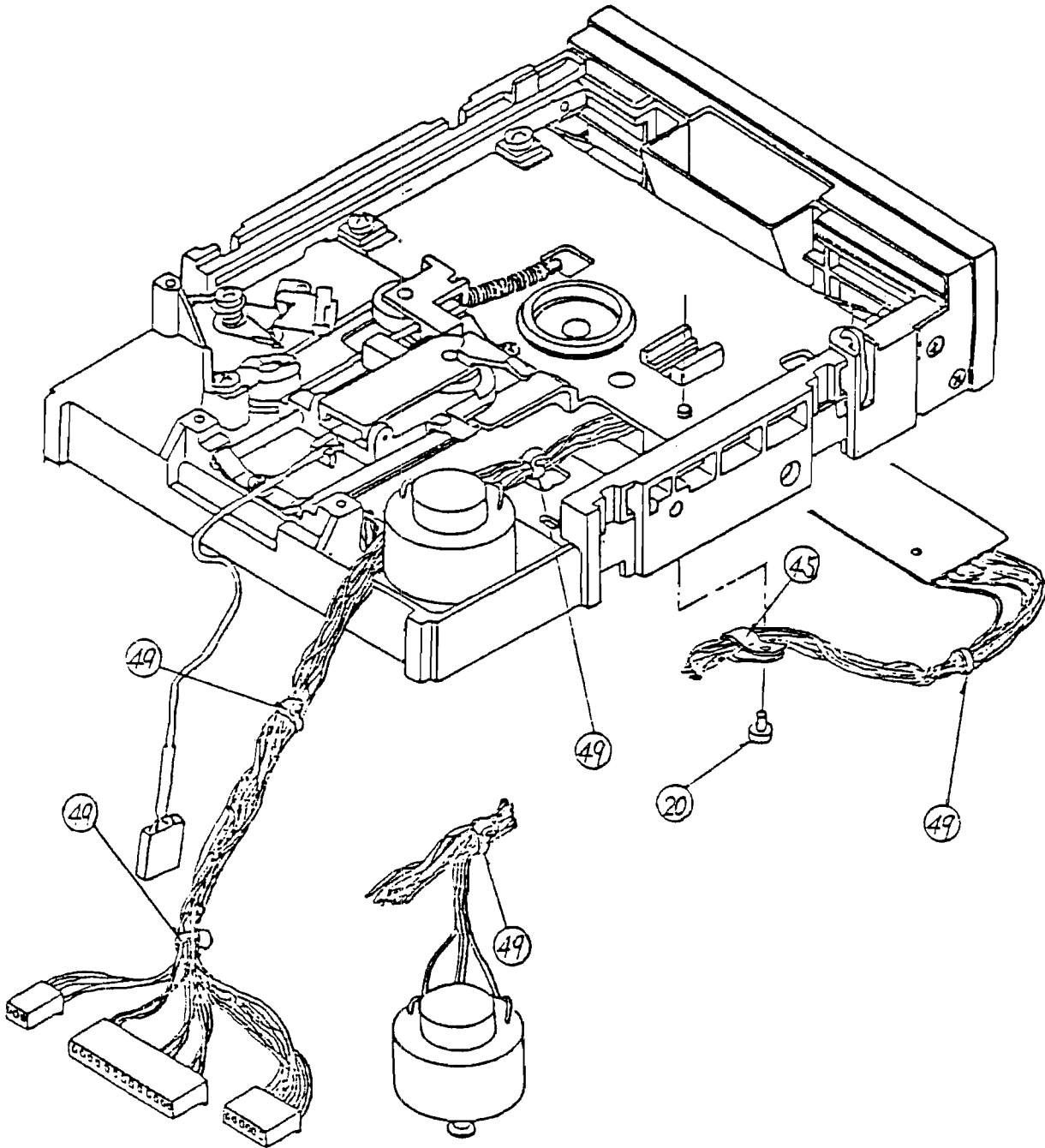
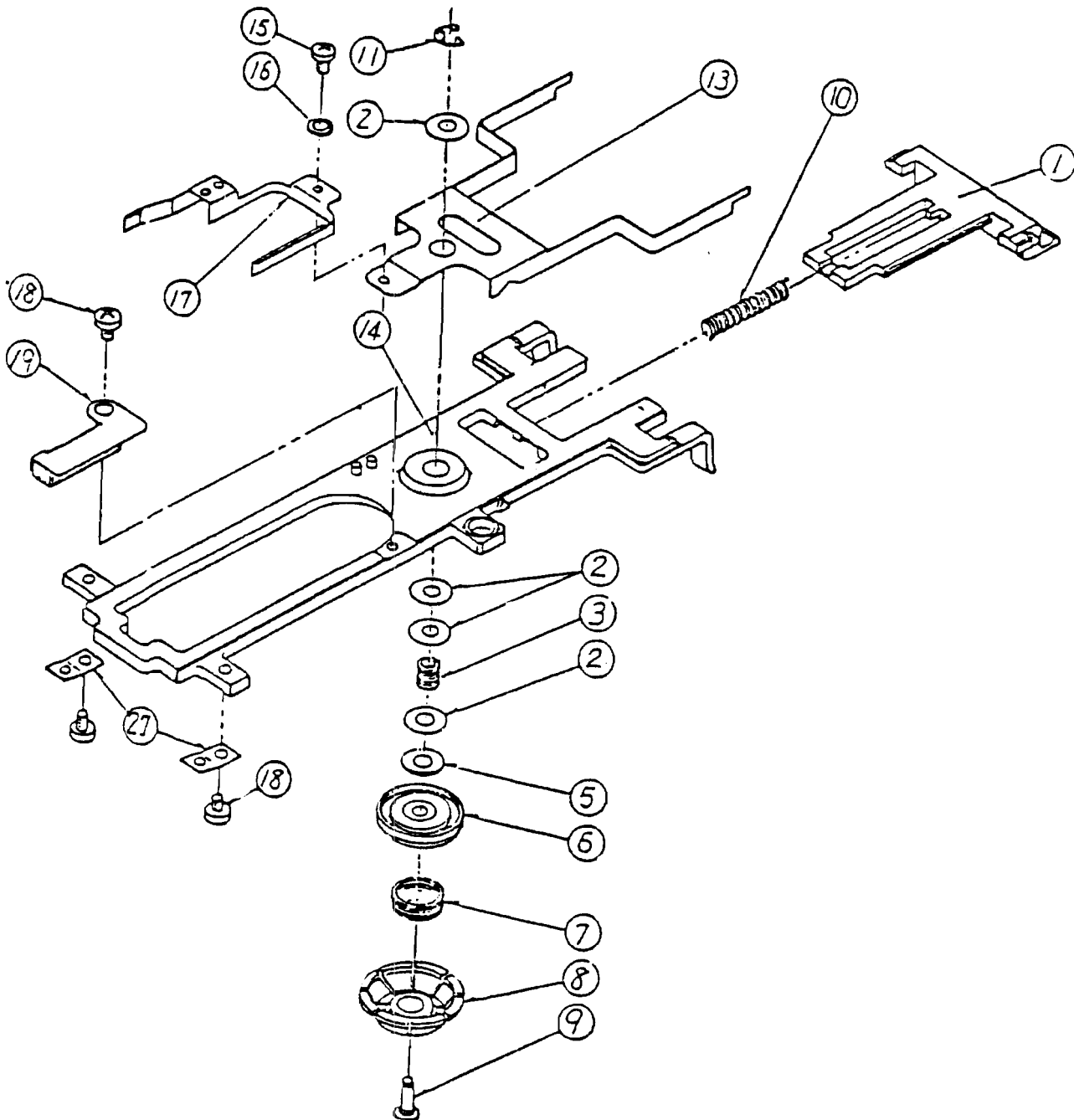

FIG 9

Part	Description	Part	Description
1	door assembly	13	hub support
2	collar	14	hub frame
3	clamp spring	15	binder screw
5	thrust washer	16	spring washer
6	collet assembly	17	arm support assembly
7	hub spring	18	binder screw
8	hub	19	pad plate assembly
9	hub shaft	27	hinge spring
10	door spring	60	collet
11	E-washer	61	collet bearing



2.3.8 FIG. 4, Diskette guide, LED assembly and connector housing.

Part	Description
31	LED assembly
43	diskette guide
52	connector housing

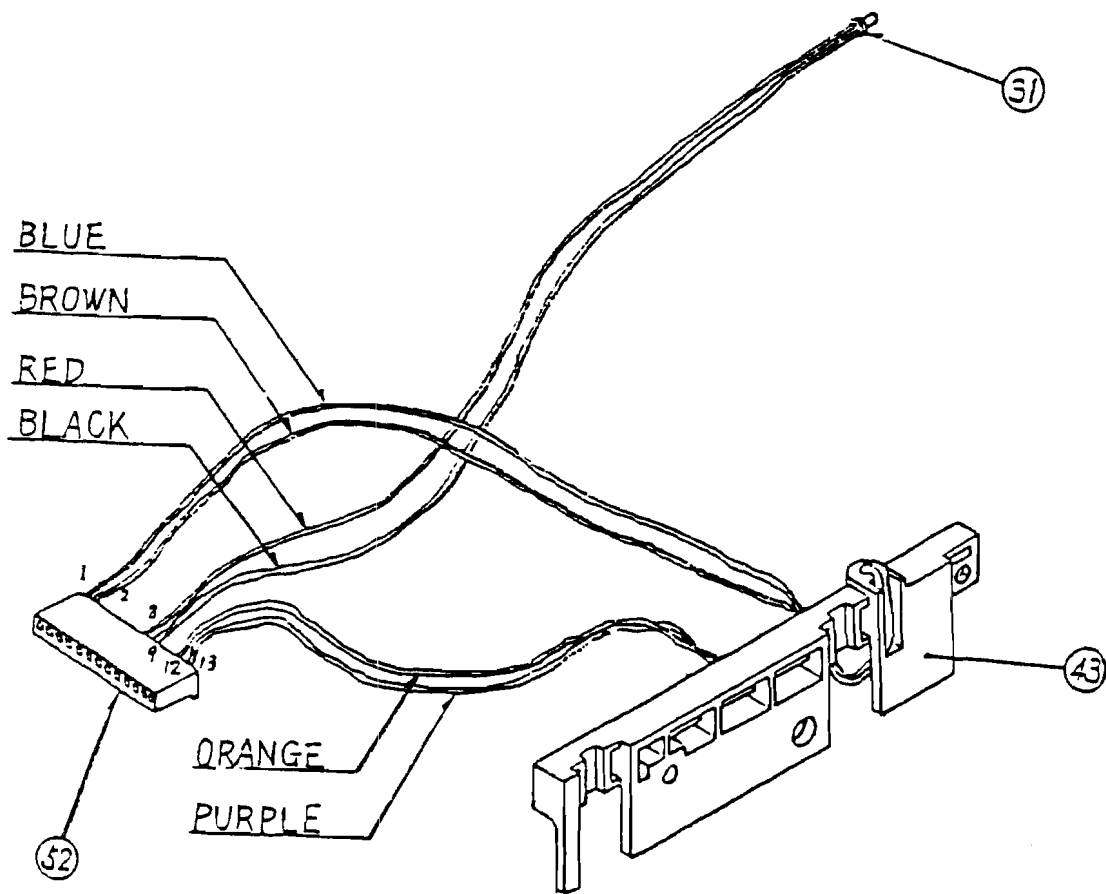

- 2.3.9 Secure the D.C. motor from the reverse side of the housing assembly with two screws.
- 2.3.10 Put the motor control PCB into hole 'A' and secure it with two screws.
- 2.3.11 Secure the stepping motor with two screws.
- 2.3.12 Secure the carriage stopper with a screw.
- 2.3.13 Install the connector housing '52' into the hole 'B' and remove through hole 'C'.
- 2.3.14 Secure the two diskette guides '21' and '43' with two screws each.
- 2.3.15 Install the LED holder in the front panel.
- 2.3.16 Insert the LED assembly into the LED holder ring.
- 2.3.17 Install the led into the LED holder, then push the LED holder ring onto the LED holder.
- 2.3.18 Attach the front panel with four flush screws.
- 2.3.19 Secure the eject plate with a screw.
- 2.3.20 Wind the metal band around the tension pulley.
- 2.3.21 Insert the guide shafts into the head assembly. Install the tension pullet as shown in figure 8
- 2.3.22 Secure the guide shaft keepers by two screws each.
- 2.3.23 Wind the metal band around the stepper pulley and secure it with a screw to the stepper motor pulley.
- 2.3.24 Hook the spring to the tension pulley and install unit in the slot in the housing assembly.
- 2.3.25 Hook the opposite end of the spring to the housing assembly.
- 2.3.26 Fasten cable ties to the cables.
- 2.3.27 Secure the cable clamp with a screw as shown in FIG 8.
- 2.3.28 Secure the arm support assembly with a screw to the hub support.
- 2.3.29 Insert the hub shaft into the hub, the hub spring, the collet assy, the thrust washer, the collar, the clamp spring and two collars.
- 2.3.30 Insert the hub shaft into the frame and the hub support and fasten it at the E-washer.
- 2.3.31 Set the door assembly and the door spring at the hub frame.
- 2.3.32 Secure the pad plate assembly with a screw to the frame at the location shown in FIG 9
- 2.3.33 Secure the two hinge springs with two screws each.

FIG. 5

Part	Description
18	binder screw
20	binder screw
37	washer
41	spring washer
42	carriage stopper
44	motor control PCB
50	stepping motor assembly

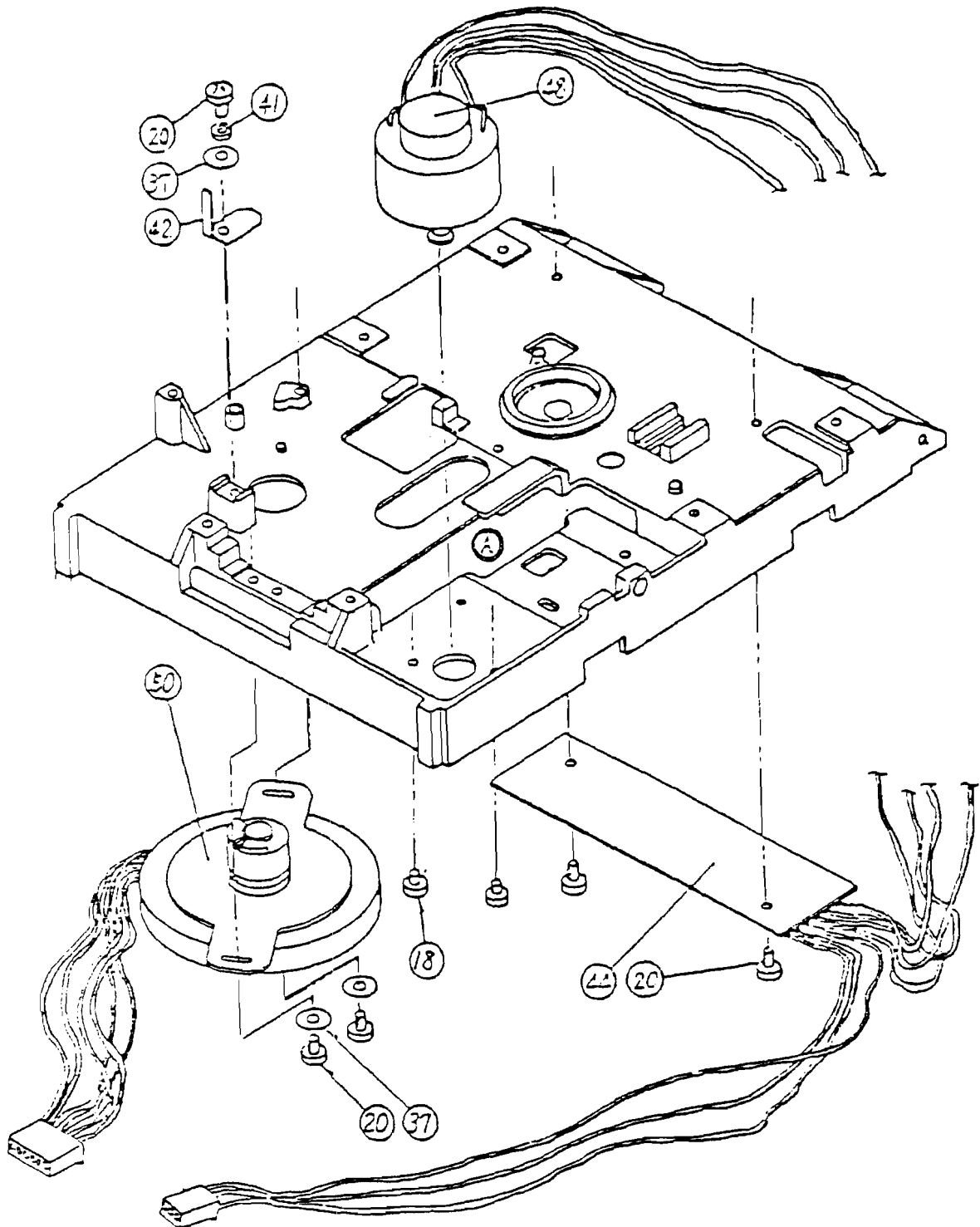

- 2.3.36 Place the belt over the D.C. motor pulley and partially on the spindle pulley.
- 2.3.37 By turning the spindle pulley the rest of the belt will seat completely on the pulley.
- 2.3.38 FIG 10

Part	Description
12	drive belt

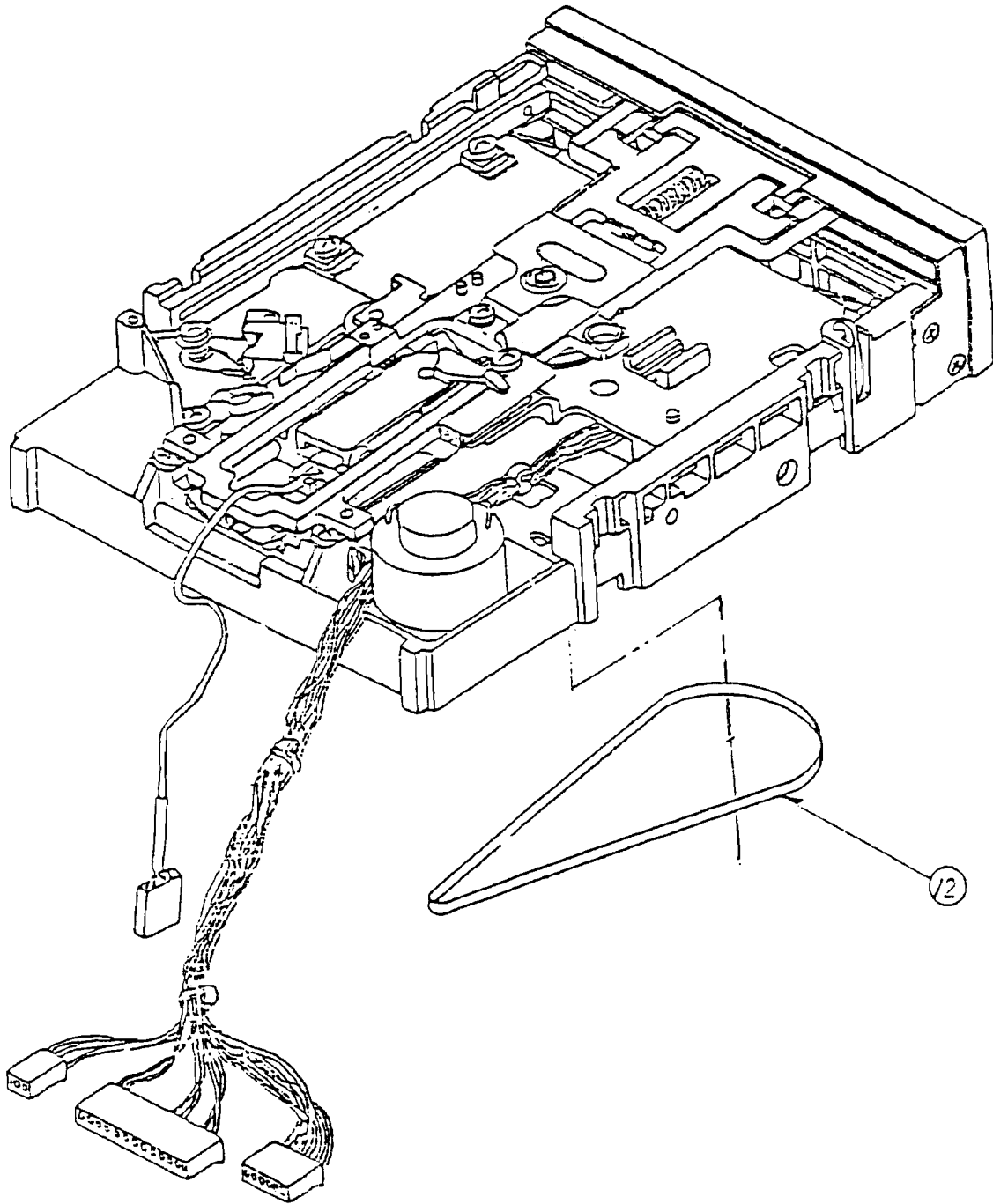

2.3.39 FIG 11; Completed Drive Mechanism

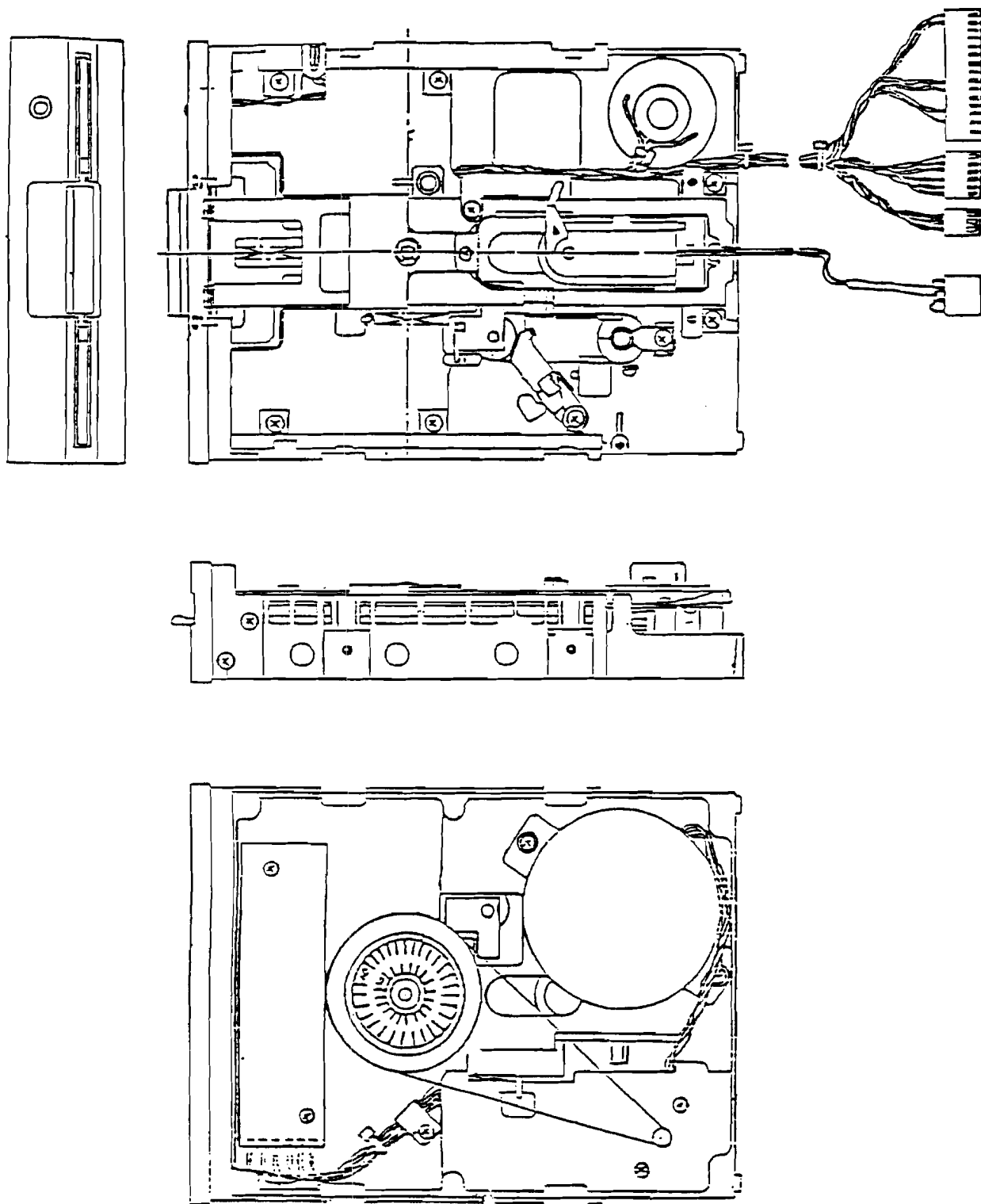

### 3.1 Description

Since the disk drive is placed under direct control of the interface and power supply, no special procedure is required for starting and operation.

### 3.2 Operating procedure

Make sure that the power supply and I/O connector are connected, then insert the disk in accordance with the following procedure.

#### 3.2.1 Inserting the media

- a) Apply DC voltage to the drive.
- b) Open the front door.

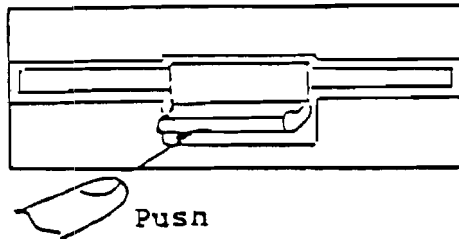

- c) With the index hole and write protect notch being placed on the left side of the jacket, push the media in, when the media is fully inserted the locking action can be felt.
- d) Push the door downward and close the door so that it is locked firmly

#### 3.2.2 Extracting the media

- a) Open the front door. The media will pop out automatically to a position where you can extract it easily.
- b) For protection of the recorded data, the media should always be stored in its envelope.
- c) Close the door of the drive.

### 3.3 Media handling procedure

Since the media has been subjected to a write operation it naturally contains information, adequate attention must be paid to its handling.

In order to extend the life of the media and eliminate the causes of errors, it is best to take the following steps:

- a) When writing something on the jacket label of the media, do **not** use a ball point pen or pencil, use felt-tipped pens.
- b) **Do not** hold the edges of the media with paper clips or the like.
- c) **Do not** touch the media exposed in the slot of the jacket.
- d) **Do not** attempt to clean the media.
- e) **Do not** keep the media in the areas where there is a strong magnetic field.
- f) The diskette should be kept in its jacket.
- g) Special care should be exercised so that the media is kept free from liquid, dust, metal particles, etc.
- h) Take care not to exceed the following environmental conditions:
  - Temperature            10 to 51°C
  - Relative humidity    8 to 80 %

#### 3.4 Seek error

Few seek errors will be experienced due to the low stepping rate, less than 12 msec/track. In case of a seek error, however, recalibration of track position can be performed. This can be done by repeatedly stepping the head towards track 0 until track 0 status is detected.

#### 3.5 Write error

In order to check the quality of the data, perform a read-after-write operation. When data can not be read, rewrite that track and sector once again.

When data can not be read after four such operations track is defective.

#### 3.6 Read error

What happens quite often when performing a read operation is a soft error. A soft error is defined to be a read error which is recoverable by making ten or less read operations. However, in the event no recovery is made in ten operations, move one step from the track in the same direction as the previous step, then return one step. If this fails to read the data, this error is unrecoverable.

### 3.7 Description

Periodic maintenance is indispensable so that this type of peripheral equipment operates properly. It is particularly important to periodically clean the head and check the load pad. Repairs and adjustments should be made in accordance with the procedures below.

### 3.8 Head Cleaning

Check for excessive dust or magnetic oxide on the load pad. With the door open (do not move upper arm greater than what is provided by opening the front door) clean head with lint free cotton cloth or 'Q-tip' in 91% isopropyl alcohol. Wipe the head carefully to remove any dust and/or oxide.

### 3.9 Adjustment procedure

In case of a malfunction or parts replacement, make the following adjustments. In order to maintain the interchangeability of the media between drives it is desirable to check each drive against a master alignment diskette.

#### 3.9.1 Track adjustment (radial track)

- a) Connect I/O cable and restore the head to track 00.
- b) Insert a 48tpi alignment diskette and close the door.
- c) Connect two oscilloscope probes to pin 1 and pin 14 of UH6 (592), set oscilloscope to analog mode at 50mV/cm and 200 msec/div.
- d) Load the head and allow it to seek to track 16, check for cats eye wave form. When the cats eye lobe ratio is 70% or less, loosen the stepping motor mounting screws, turn the stepping motor to obtain the lobe ratio of 90% or less.
- e) After allowing the head to track 34, return it to track 16 and recheck the cats eye. If the ratio is correct tighten the stepping motor screws.

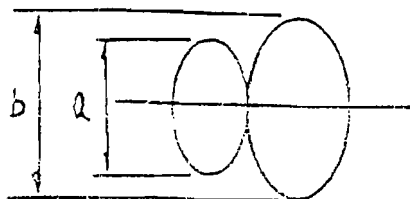

$$\frac{a}{b} \times 100 \geq 70$$

Cats eye lobe ratio

### 3.9.2 Track 00 adjustment

The drive is not provided with a track 00 sensor. To adjust, let the head over step in the track 00 direction and adjust the limiter position to obtain a clearance less than 0.25mm (0.01inches).

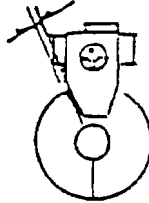

### 3.9.3 Speed control

Turn the variable resistor on the motor control board until the tachometer disk on the spindle pulley appears stationary when viewed with a fluorescent lamp.

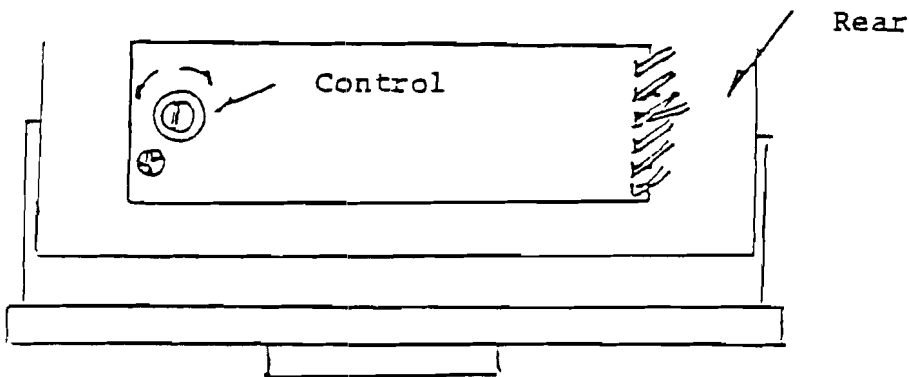

PART NO.	DESCRIPTION
1540048-01	FCC (UL) PCB ASSY. VIC-1541. USED LOGIC ARRAY.

[Print Name]

TITLE: PCB ASSY. VIC-1541				
<b>REVISIONS</b>				
LTR	ZONE	DESCRIPTION	DATE	APPROVED
A		PRODUCTION RELEASE	1/10/82	T. MATSUMOTO
B		REVISED PER ECO 830085	2/20/83	H. Okada
C		REVISED PER ECO 830125	3/25/83	H. Okada

1540048

21

1. SHEET 7 OF 8 OF 8 ARE B-SIZE  
ASSY DWG  
NOTES-UNLESS OTHERWISE SPECIFIED:

<b>commodore</b>	DRAWN BY: <i>T. Takubo</i>	DATE: 11/16/82	ENGR: <i>T. MATSUMOTO</i>	SIZE: B	SHEET 1 of 8
	CHKD:		APPR: <i>T. MATSUMOTO</i>	DATE: 1/10/82	

QUANTITY REQD PER PART / DASH NO.				ITEM	B	PART NUMBER	DESCRIPTION	REF DES	BEND	NOTES
			02 01	1	B	1540050	PC BOARD 238 x155 x1.6t			GLASS EPOXY. G-10
				2						
				3						
				4						
				5	C	1540049-01	SCHEMATIC DIAGRAM			USED LOGIC ARRAY. FCC (UL)
				7						
				8						
				9						
				10						
				11						
				12	B	901435-01	IC MPS 6502 CPU	UC4		
				13		901437-01	MPS 6522 VIA	UC2, UC3		
				14		901229-03	2364-197 ROM	UB4		\$E000 ~ \$FFFF
				15		325302-01	2364-130 ROM	UB3		\$C000 ~ \$DFFF
				16		325572-01	LOGIC ARRAY 40 PIN DIP	UC1		
				17		901521-01	74LS00 2-NAND	UC6		
				18		901521-17	74LS42 DEC.	UC7		
				19		901522-01	7417 BUFFER	UD2		
				20		901521-32	74LS86 2-EX-OR	UD3		
				21		901522-06	7406 INV. BUF.	UB1, UD1		
				22		901521-02	74LS04 INV.	UC5		
				23		901521-30	74LS14 SCH. INV.	UA1		
				24		901521-26	74LS193 4 BIT. COU.	UE6		
				25		901521-54	74LS197	UD5		
				26	S	901522-03	74177	UD5		SUBSTITUTE FOR ITEM 25.
				27		901510-01	9602	UD4		
				28		901523-04	LM311	UE4		
				29	B	901523-08	IC NE592	UF3, UF4		
				30	B	325502-03	IC TMM2016P RAM	UB2		
				31	B	325502-01	IC M58725P RAM	UB2		SUBSTITUTE FOR ITEM 30.
				32	B	901522-30	IC 7407	UD2		SUBSTITUTE FOR ITEM 19.
				33						
				34						
				35						
				36						
				37						

22

commodore

TITLE: PCB ASSY. VIC-1541

DRAWN BY:  
T. Tokuo  
CHKD:DATE  
11/16/82ENGR: 710  
APPR: T.M.DATE  
12/17  
12/18SIZE  
B

1540048

REV  
CSHT  
2/8

QUANTITY REQD PER PART / DASH NO.				ITEM	Q	PART NUMBER	DESCRIPTION	REF DES	BEND	NOTES
				01						
				2	38	B	902671	TRANSISTOR NPN 2SC945	Q2, Q7	
				S	39		902693-01	2SC1815	Q2, Q7	SUBSTITUTE FOR ITEM 38.
				4	40		902679	2SD467	Q8 - Q11	
				S	41		902682	NPN 2SC2120	Q8 - Q11	SUBSTITUTE FOR ITEM 40.
				1	42		902720	PNP 2SA673	Q1	
				4	43		902717	2SA733	Q3 - Q6	
				S	44	B	902744-01	TRANSISTOR PNP 2SA1015	Q3 - Q6	SUBSTITUTE FOR ITEM 43.
					45					
					46					
					47					
					48					
					49					
					50					
					51					
				6	52	B	900750-02	DIODE, RECTIFIER IN4002	CR2,4,8-11	
				8	53		900850-05	SIGNAL WGT13C	CR6,7,12,14-18	
				S	54		900850-01	SIGNAL IN4148	CR6,7,12,14-18	SUBSTITUTE FOR ITEM 53.
				1	55		325505-01	ZENER 3.3V 500 mW ±5%	CR5	HE3C-2
				S	56		325505-02	3.3V 500 mW ±5%	CR5	HE4A-1 SUB. FOR ITEM 55.
				S	57		900948-06	3.3V 500 mW ±5%	CR5	IN3226B SUB. FOR ITEM 55.
				1	58		325506-01	5.1V 500 mW ±5%	CR13	HE3C-2
				S	59		900948-11	ZENER 5.1V 500 mW ±5%	CR13	IN5231 SUB. FOR ITEM 58.
				2	60	B	900756-01	DIODE BRIDGE 1.5A 50V	CR1, CR3	KBP-005
					61					
					62					
					63					
				1	64	B	325566-01	CRYSTAL MODULE 16 MHz 50 PPM	Y1	
				S	65	B	325566-02	CRYSTAL MODULE 16 MHz 100 PPM	Y1	SUBSTITUTE FOR ITEM 64.
					66					
					67					
					68					
				1	69	B	325513-01	COIL, INDUCTOR 2.2 μH	L1	
				2	70	B	325513-02	COIL, INDUCTOR 22 μH	L9, L10	
				3	71	B	325513-03	COIL, INDUCTOR 100 μH	L8, L11, L12	
					72					
					73					
					74					

commodore

TITLE: PCB ASST. VIC-1541

DRAWN BY: J. Tokuda  
CHKD:

DATE: 11/16/82

ENGR: J/C  
APPR: J/C

DATE: 12/17  
1982

SIZE: B

1540048

REV: C  
SHT: 3/8

QUANTITY REQD PER PART / DASH NO.										ITEM	Q	PART NUMBER	DESCRIPTION	REF DES	BEND	NOTES	
										01							
										1	76	B	901528-04	VOLTAGE REGULATOR 12V.1.5A	VR1		LM340-12 T0-3
										1	76	B	901528-03	VOLTAGE REGULATOR 5V.1.2A	VR2		LM340-5 T0-3
											77						
											78						
										2	79	B	904914	INSULATION MYLAR T0-3			
										S	80	B	325551-01	INSULATION SILICONE T0-3			SUBSTITUTE FOR ITEM 79.
											81						
											82						
										2	83	B	903361	CONNECTOR, DIN 6P	P2, P3		
											84						
											85						
											86						
										4	87	B	904150-06	SOCKET IC LOW PRO 40 PIN			
										3	88	B	904150-03	SOCKET IC LOW PRO 24 PIN			
											89						
											90						
											91						
											92						
											93						
											94						
											95						
										1	96	B	251065-04	HEADER ASSY. 2.5 PITCH 4PIN	P8		MOLEX 5048-04 A4
										1	97		325562-06	6PIN	P7		3022-06A
										1	98		325562-15	15PIN	P6		3022-15A
										2	99		325562-03	2.5 PITCH 3PIN	P4, P5		3022-03A
										1	100	B	903316-04	HEADER ASSY. 3.96 PITCH 4PIN	P1		MOLEX 5271-04A
											101						
											102						
											103						
											104						
											105						
											106						
											107						
											108						
											109						
											110						
											111						

<b>commodore</b>		TITLE: PCB ASSY. VIC-1541	DRWN BY: T. Takuda	DATE: 10/12/82	ENGR: <i>70</i>	DATE: 12/77	SIZE: B	1540048	REV: C	SHT: 4/8
			CHKD:		APPR: <i>74</i>	DATE: 12/18				

QUANTITY REQD PER PART / DASH NO.		ITEM	B	PART NUMBER	DESCRIPTION	REF DES	BEND	NOTES
		01						
		1	112	B 900301-04	CAPACITOR ELECT. 220µF/10V	C13		
		1	113	900101-45	6800µF/25V	C17		
		1	114	900101-32	4700µF/16V	C16		
		2	115	900100-33	47µF/16V	C2,C5		
		2	116	900100-32	ELECT. 1µF/25V	C1,C4		
		1	117	900402-15	TANTALIUM 10µF/25V	C15		
		1	118	900402-11	TANTALIUM 3.3µF/25V	C44		
		1	119	900010-52	CERAMIC 150µF/50V	C31		±5%
		2	120	-53	330µF/50V	C32,C36		±5%
		3	121	-54	680µF/50V	C45,C33,C34		±5%
		1	122	-25	1000µF/50V	C41		
		24	123	-20	0.1µF/50V	C3,6-10		14,18,19,20,22-30,35,40,43,47,48
		2	124	900010-14	CERAMIC 0.022µF/50V	C39,C42		
		1	125	900100-40	ELECT. 100µF/16V	C46		
		2	126	900402-17	TANTALIUM 0.47µF/25V	C37,C38		
		1	127	-08	4.7µF/25V	C21		
		1	128	900402-14	TANTALIUM 1µF/16V	C11		
		1	129	B 900465-02	CAPACITOR CERAMIC 0.033µF/25V	C12		
			130					
			131					
			132					
			133					
		1	134	B 901550-56	RESISTOR CARBON 1/4W ±5% 47Ω	R1		
		2	135	B 901550-108	RESISTOR CARBON 1/4W ±5% 360Ω	R14,R24		
		4	136	-89	150Ω	R17,18,45,46		
		4	137	-52	220Ω	R4,16,36,55		
		2	138	-14	330Ω	R3,R23		
		6	139	-58	470Ω	R20,22,30,31,39		41
		1	140	-38	510Ω	R27		
		6	141	-31	680Ω	R21,42,49-50		
		6	142	-01	1KΩ	R2,5,6,7,8,43		
		3	143	-53	2KΩ	R9,10,26		
		6	144	-18	2.2KΩ	R11,19,21,32-34		
		1	145	-69	1.5KΩ	R40		
		4	146	-12	22KΩ	R12,35,39,52		
		2	147	B 901550-07	RESISTOR CARBON 1/4W ±5% 100KΩ	R25,R44		
			148					

25

commodore	TITLE: PCB ASSY. VIC-1541	DRAWN BY: T. Zekuch	DATE: 11/16/82	ENGR: 40	DATE: 12/1	SIZE: B	REV: C	SHT: 5/8
		CHKD:		APPR: T.M.	P.P.P.		1540048	



REVISIONS

LTR	ZONE	DESCRIPTION	DATE	APPROVED
		SEE SHEET 1		

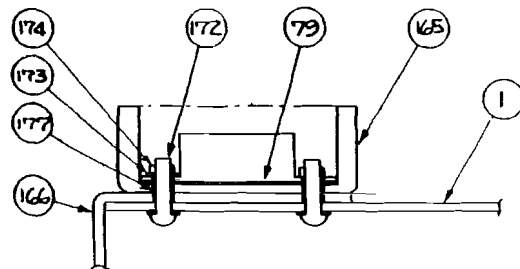
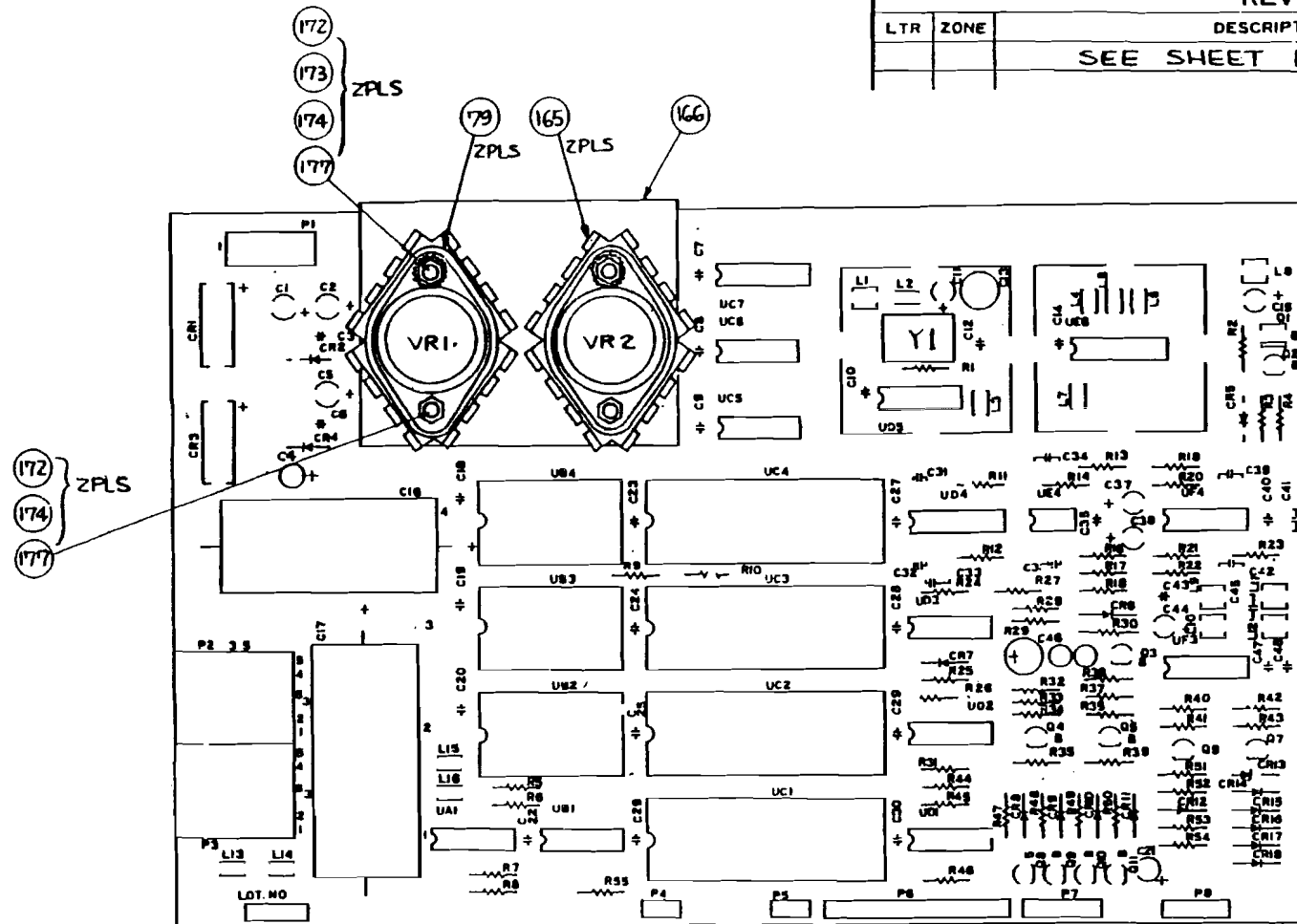

UNLESS OTHERWISE SPECIFIED TOLERANCES ON: DECIMALS .X .XX .XXX L'S ± ± ± ±	DRAWN BY: K. Matsumura CHKD: T. Fukuda ENGR: JES APPR: T. HOSOKAWA	DATE: 2/11/82 2/17/82	<b>commodore</b> P.C.B ASSY VIC-1541	
	MATERIAL: VIC-1541 FINISH:	USED ON: VIC-1541 NEXT ASSY:		
SCALE NONE			SHEET 7 OF 8	

REVISIONS		DATE	APPROVED
LTR ZONE	DESCRIPTION		
A	PRODUCTION RELEASE	1/11/78	
B	REV PER ECO 83025		

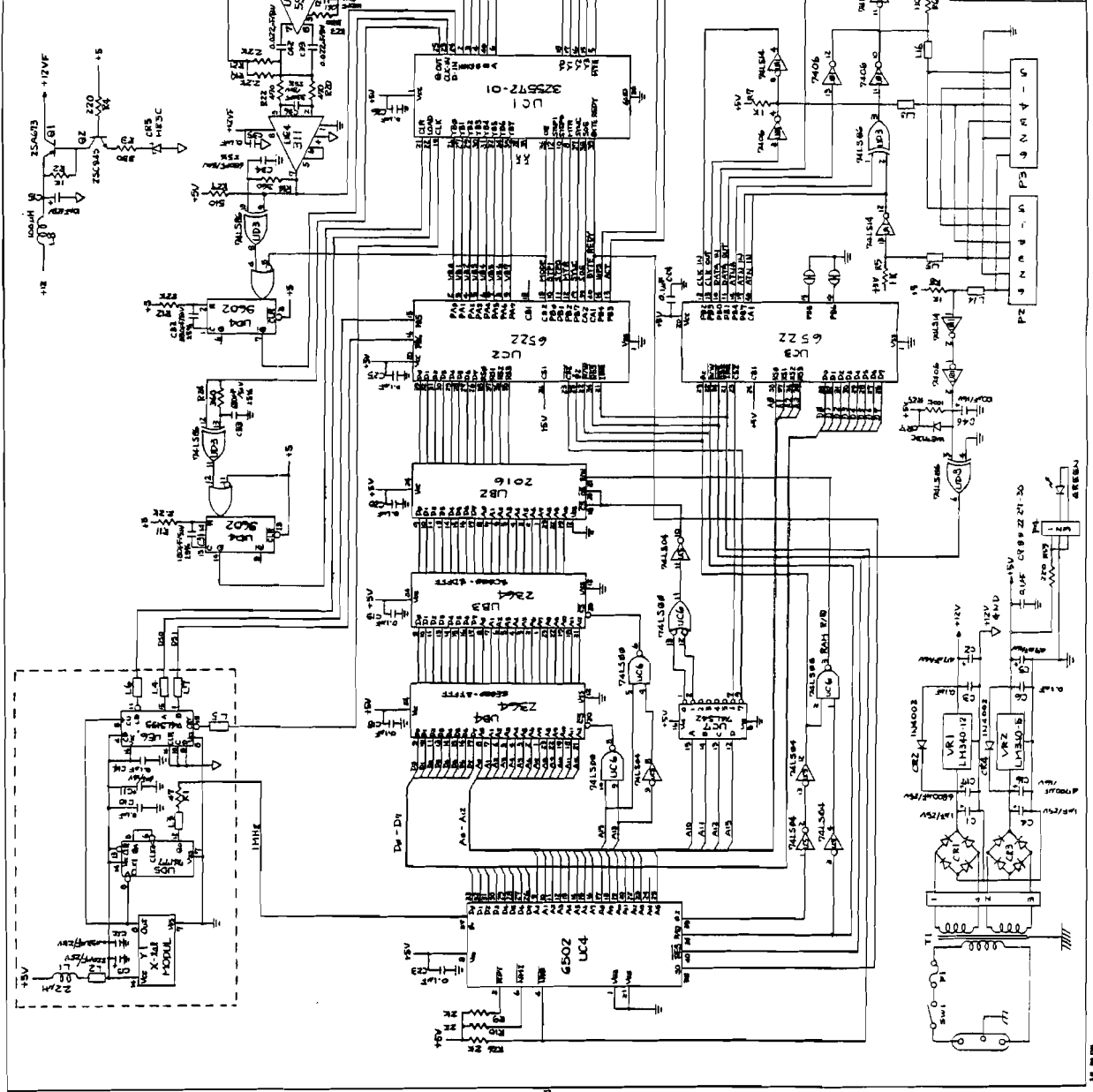

DATE	1/11/78
DESIGNED BY	K. M. ...
CHECKED BY	...
DATE	...
USED ON	...
MATERIAL	...
YIELD	...

USE THE FOLLOWING INFORMATION TO IDENTIFY THE OCCURRENCE OF THE PROBLEM:	
DATE	1/11/78
DESIGNED BY	K. M. ...
CHECKED BY	...
DATE	...
USED ON	...
MATERIAL	...
YIELD	...

<b>Commodore</b>	
SCHEMATIC DIAGRAM	
SIZE	C 1540049-01
REV	B
SCALE	SHEET 1 OF 2

PART NO.	DESCRIPTION
1540001 -01	PCB ASSY VIC-1540 (FCC) UL
1540001 -03	PCB ASSY VIC-1541 (FCC) UL

REV	DATE	DESCRIPTION	BY	CHKD
A	8/26/81	PRODUCTION RELEASE	Z.T	B.T
B	8/24/82	ADDED SHEET 6 OF 7 (FOR FCC)	Z.T	B.T
C	8/13/82	ADDED DASH -03 AND -04	Z.T	B.T
D	11/20/82	ADDED ITEM 6.	Z.T	T.M
E	3/5/83	REVISED PER ECO 830084	Z.T	B.T

2 THIS ROM CAN BE USED ON ONLY USA-CANADA AND JAPAN'S VERSION FOR SUBSTITUTE FOR ITEM 35.

1. SHEET 6&7 OF 7 ARE B-SIZE ASSY DWG.

NOTES.

c b m ENGINEERING OSAKA JAPAN	TITLE	DRAWN BY	DATE	DATE	SIZE	SHEET
	PCB ASSY VIC-1540	Y. HAGA	7/1/81	1/1	B	
		CHKD: C.T	8/26/81	1/1		1540001-
				APPR		1 of 7

QUANTITY REQD PER PART/DASH NO.		ITEM	QTY	PART NUMBER	DESCRIPTION	REF. DES	REMARKS	NOTES
	03	01	1	1540007	P.C. BOARD 3/5x155x166			MTL: GLASS EPOXY 9-10
			1					
			1					
			1					
			1	1540008-01	SCHEMATIC DIAGRAM			
			1	6 B 901229-03	IC 2364-197 ROM	UAB5		\$E000 ~ \$FFF
			1	1 7 B 901435-01	IC MPS 6502 CPU	UCD5		
			1	1 8 325302-01	2364-130 ROM	UAB4		\$C000 ~ \$DFFF
			1	1 9 325303-01	2364-131 ROM	UAB5		\$E000 ~ \$FFFF
			2	2 10 901437-01	MPS 6522 VIA	UAB1,UCD4		
			4	4 11 901471-01	MPS 2114 RAM	UA2,3,UB2,3		
			2	2 12 901521-01	74LS00 2-NAND	UB7,UF5		
			1	1 13 901521-21	74LS02 2-NOR	UE5		
			1	1 14 901521-02	74LS04 INV.	UB6		
			1	1 15 901521-24	74LS10 3-NAND	UF3		
			1	1 16 901521-30	74LS14 SCH. INV.	UC1		
			1	1 17 901521-17	74LS42 DEC.	UB8		
			2	2 18 901521-06	74LS74 D-FF	UE4,UF6		
			1	1 19 901521-32	74LS86 2-Ex-OR	UG2		
			1	1 20 901521-15	74LS133 13-NAND	UC2		
			1	1 21 901521-18	74LS139 Dem. P	UE2		
			1	1 22 901521-28	74LS164 8 Bit Shift Reg	UD2		
			1	1 23 901521-12	74LS165 8 Bit Shift Reg	UD3		
			1	1 24 901521-40	74LS191 4 Bit Count.	UE3		
			2	2 25 901521-26	74LS193 4 Bit Count.	UE7,UF4		
			1	1 26 901521-45	74LS245 Bus Transceiver	UC3		
			1	1 27 901522-32	7402	UC7		
			2	2 28 901522-06	7406 INV. OC.	UD1,UF2		
			1	1 29 901522-03	74177	UC6		
			1	1 30 901510-01	9602	UG3		
			1	1 31 901523-04	LM311	UH4		
			2	2 32 B 901523-08	NE592	UH5,UH7		
			1	1 33 B 901522-01	7417	UG4		
			S	S 34 B 901521-54	74LS197	UC6		SUBSTITUTION FOR ITEM 29
			S	S 35 B 901229-02	2364-186 ROM	UAB5		\$E000 ~ \$FFFF SUB. FOR ITEM 6.
			S	S 36 B 901229-01	IC 2364-173 ROM	UAB5		\$E000 ~ \$FFFF SUB. FOR ITEM 6. [2]

c b m ENGINEERING  
OSAKA JAPAN

TITLE: PCB ASSY VIC-1540

DRAWN BY: DATE: 1/1  
CHKD: G. Takane 8/24/81 APPR:

DATE: 1/1 SIZE: B SHEET: 1540001-2 of 7

QUANTITY REQD PER PART/DASH NO.				ITEM	QTY	PART NUMBER	DESCRIPTION	REF. DES	REMARKS	NOTES
				03	01					
				2	2	37 B 902671	TRANSISTOR NPN 2SC945	Q2, Q3		
				S	5	38 902693-01	NPN 2SC1815	Q2, Q3		SUBSTITUTION FOR ITEM 37
				4	4	39 902679	NPN 2SD467	Q4-Q7		
				S	5	40 902682	NPN 2SC2120	Q4-Q7		SUBSTITUTION FOR ITEM 39
				1	1	41 902720	PNP 2SA673	Q1		
				4	4	42 902717	PNP 2SA733	Q8-Q11		
				S	5	43 B 902744-01	TRANSISTOR PNP 2SA1015	Q8-Q11		SUBSTITUTION FOR ITEM 42
				S	5	44 B 901522-30	IC 7407	U64		SUBSTITUTION FOR ITEM 33
						45				
				6	6	46 B 900750-02	DIODE, SIGNAL 1N4002	CR2, 13-16		
				8	8	47 900850-05	SIGNAL WG 713C	CR6-11, 17, 18		
				S	5	48 900850-01	SIGNAL 1N4148	CR6-11, 17, 18		SUBSTITUTION FOR ITEM 47
				1	1	49 325505-01	ZENER 3.3V 500mW ±5%	CR5		HZ3C-2
				S	5	50 325505-02	3.3V 500mW ±5%	CR5		HZ4A-1 SUB. FOR ITEM 49
				S	5	51 900948-06	3.3V 500mW ±5%	CR5		1N5226B SUB. FOR ITEM 49
				1	1	52 325506-01	5.1V 500mW ±5%	CR12		HZ5C-2
				S	5	53 900948-11	ZENER 5.1V 500mW ±5%	CR12		1N5231 SUB. FOR ITEM 52
				1	1	54 900756-01	BRIDGE 1.5A 50V	CR1		KBP005
				1	1	55 B 900755-02	DIODE, BRIDGE 4A 50V	CR3		KBL-02
						56				
				1	1	57 B 900556-02	CRYSTAL 16MHz	Y1		
						58				
				1	1	59 B 325513-01	COIL, INDUCTOR 2.2μH	L1		
				2	2	60 B 325513-02	COIL, INDUCTOR 22μH	L8, L11		
				3	3	61 B 325513-03	COIL, INDUCTOR 100μH	L7, L9, L10		
						62				
				1	1	63 B 901528-04	VOLTAGE REGULATOR 12V 1.5A	VR1		LM340-12
				1	1	64 B 901528-01	VOLTAGE REGULATOR 5V 3A	VR2		LM323
				2	2	65 B 904914	INSULATION MYLAR 70-3			ATTACHED WITH VOLT REGULATOR
				S	5	66 B 325551-01	INSULATION SILICONE 70-3			SUBSTITUTION FOR ITEM 65.
						67				
				2	2	68 B 903361	CONNECTOR, DIN 6PIN	P3, P4		HOSHIDENKI TCS4460-01-101
						69				
				3	3	70 B 904150-06	SOCKET IC LOW PRO. 40PIN			
				2	2	71 B 904153-03	SOCKET IC LOW PRO. 24PIN			
						72				

c b m ENGINEERING  
OSAKA JAPAN

TITLE:  
PCB ASSY VIC-1540

DRAWN BY:  
CHKD. f. Jahnke 8/24/81

DATE  
1/1  
APPR:

DATE  
1/1  
SIZE  
B

1540001-3 of 7

QUANTITY REQD PER PART/DASH NO.				ITEM	QTY	PART NUMBER	DESCRIPTION	REF. DES	BOM	NOTES
				1	1	73 B	325514-04	HEADER ASSY 2.5 DICH R-ANG. 4PIN	P2	MOLEX 5049-04AG
				1	1	74	325515-06	6PIN	P7	3094-06A
				1	1	75	325515-15	15PIN	P6	3094-15A
				2	2	76 B	325515-03	2.5 DICH R-ANG. 3PIN	P5, P8	3094-03A
				1	1	77 B	903316-04	HEADER ASSY 3.96 DICH 4PIN	P1	MOLEX 5271-04A
						78				
				1	1	79 B	900100-03	CAP. ELECTROLYTIC 220 $\mu$ F/25V	C65	
				1	1	80 B	900101-44	CAP. ELECTROLYTIC 10000 $\mu$ F 16V	C52	AXIAL LEAD $\phi$ 22x52
				1	1	81	900101-45	6800 $\mu$ F 25V	C51	AXIAL LEAD $\phi$ 22x52
				2	2	82	900100-33	47 $\mu$ F 16V	C2, C5	
				2	2	83	900100-32	ELECTROLYTIC 1 $\mu$ F 25V	C1, C4	
				1	1	84	900402-15	TANTALIUM 10 $\mu$ F 25V	C12	
				1	1	85	900402-11	TANTALIUM 3.3 $\mu$ F 25V	C23	
				1	1	86	900010-51	CERAMIC 68PF 50V	C10	
				1	1	87	900010-52	150PF 50V	C33	$\pm$ 5%
				2	2	88	900010-53	330PF 50V	C28, C49	$\pm$ 5%
				3	3	89	900010-54	680PF 50V	C16, C27, C50	$\pm$ 5%
				1	1	90	900010-25	1000PF 50V	C26	
				40	40	91	900010-20	0.1 $\mu$ F/50V	C3, 6, 9, 11, 13, 14, 17-22	28, 29-32, 34-48, 53-55, 57, 60, 61
				2	2	92	900010-14	CERAMIC 0.022 $\mu$ F 50V	C58, C59	
				1	1	93	900100-40	ELECTROLYTIC 100 $\mu$ F 16V	C56	
				2	2	94 B	900402-17	CAP. TANTALIUM 0.47 $\mu$ F 16V	C15, C24	$\pm$ 20%
				1	1	95 B	900402-08	CAP. TANTALIUM 4.7 $\mu$ F/25V	C62	
				1	1	96 B	900402-14	CAP. TANTALIUM 1 $\mu$ F/10V	C63	
				1	1	97 B	900465-02	CAP. CERAMIC 0.033 $\mu$ F/25V	C64	
				2	2	98 B	901550-108	RESISTOR, CARBON $\frac{1}{4}$ W 5% 360 $\Omega$	R26, R30	
				1	1	99 B	901550-56	RESISTOR, CARBON $\frac{1}{4}$ W 5% 47 $\Omega$	R3	
				4	4	100 B	901550-89	RESISTOR, CARBON $\frac{1}{4}$ W 5% 150 $\Omega$	R8, 19, 35, 36	
				4	4	101	901550-52	220 $\Omega$	R4, 16, 17, 45	
				5	5	102	901550-14	330 $\Omega$	R1, 2, 5, 20, 37	
				6	6	103	901550-58	470 $\Omega$	R27, 28, 47, 50, 55, 57	
				1	1	104	901550-38	510 $\Omega$	R24	
				5	5	105	901550-31	680 $\Omega$	R9, R39-R42	
				8	8	106	901550-01	1 K $\Omega$	R6, 11, 31-34, 44, 52	
				4	4	107	901550-53	2 K $\Omega$	R21-R23, R38	
				6	6	108 B	901550-18	RESISTOR, CARBON $\frac{1}{4}$ W 5% 2.2K $\Omega$	R4, 15, 24, 51, 62, 66	

c b m ENGINEERING  
OSAKA JAPANTITLE:  
PCB ASSY VIC-1540

DRAWN BY:

DATE

1/1

CHKD:

P. Takai 12/1/91

APPR:

DATE

1/1

SIZE

B

1540001-

SHEET

4 of 7

QUANTITY REQD PER PART/DASH NO.										ITEM	#	D	PART NUMBER	DESCRIPTION	REF. DES	BEND	NOTES
										1	109	B	901550-69	RESISTOR, CARBON 1/4W 5% 1.5K $\Omega$	R88		
										4	110	B	901550-12	RESISTOR, CARBON 1/4W 5% 22K $\Omega$	R7,10,29,53		
										2	111	B	901550-07	RESISTOR, CARBON 1/4W 5% 100K $\Omega$	R43, R46		
											112						
										1	113	B	901751-43	RESISTOR, METAL OXIDE 1/4W 1% 91 $\Omega$	R8		
										1	114	B	901751-18	RESISTOR, METAL OXIDE 1/4W 1% 100 $\Omega$	R49		
										1	115	B	901751-44	RESISTOR, METAL OXIDE 1/4W 1% 150 $\Omega$	R54		
										2	116	B	901751-45	RESISTOR, METAL OXIDE 1/4W 1% 9.1 K $\Omega$	R12, R13		
											117						
											118						
											119						
											120						
										10	121	B	903025-01	FERRITE BEAD	L2-L6, L12-L16		
											122						
											123						
										2	124	B	4022048	SHIELD BOX			
										2	125	B	4022047	SHIELD CAP			
										2	126	B	1540023	HEAT SINK T0-3			
										1	127	B	1540011	HEAT SINK REGULATOR			
										1	128		904907-01	COMPOUND THER FOR HEAT SINK			CONJUNCTION WITH ITEM 65
											129						
											130						
											131						
										4	132	B	906800-02	SCREW PAN HEAD M3x10			
										4	134	B	905655-03	EXTERNAL TOOTH WASHER M3			
										4	135	B	905960-03	NUT HEX. M3			
											136						
										4	137	B	905477-02	TUBE VINYL $\phi$ 3.5 x L5mm			
											138						
											139						
											140						
											141						
											142						
											143						
											144						
											145						

c b m ENGINEERING  
OSAKA JAPAN

TITLE: PCB ASSY VIC-1540

DRAWN BY: DATE: 11  
CHKD: G. Takai 8/21/81 APPR:

DATE: 11 SIZE: B

1540001- 5 of 7

REVISIONS				
LTR	ZONE	DESCRIPTION	DATE	APPROVED
		SEE SHEET 1		<i>dt</i>

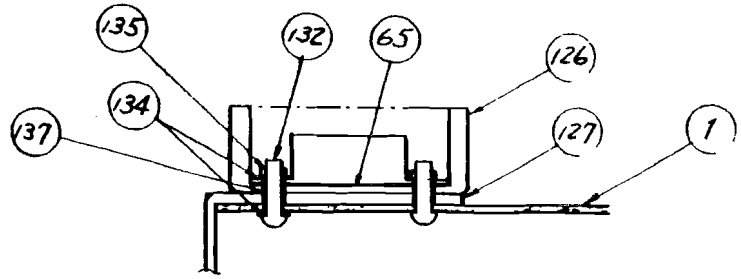
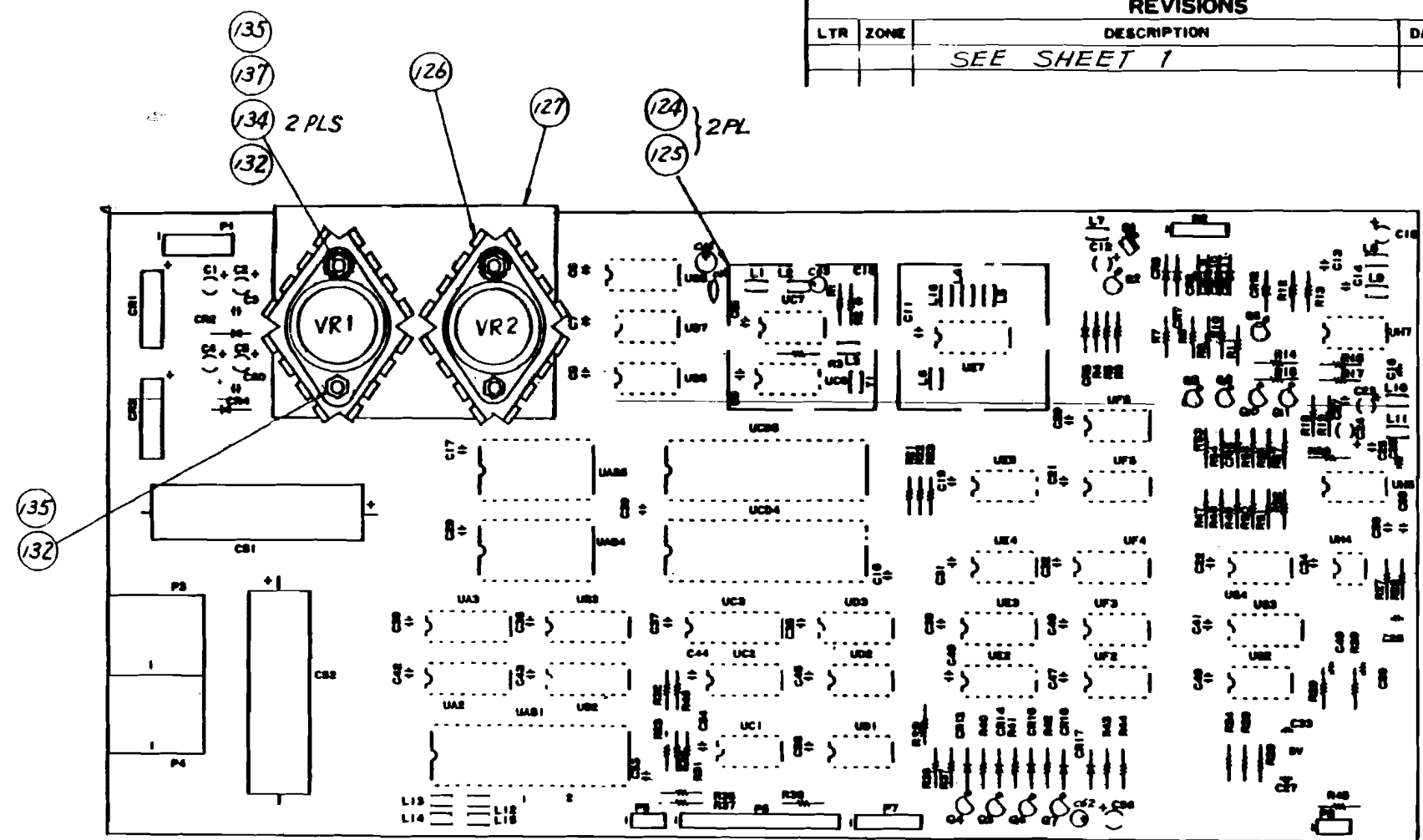

UNLESS OTHERWISE SPECIFIED TOLERANCES ON: DECIMALS .X    .XX    .XXX    .X'S	DRAWN BY: <i>T. Takano</i>	DATE: <i>8/4/01</i>	<b>C b m</b> OSAKA JAPAN
	MATERIAL: FRESH:	USED ON: VIC-1540 VIC-1541	
PCB ASSY. VIC-1540			REV <b>E</b>
SIZE <b>B</b>		1540001-01/03	SCALE NONE    SHEET 6 OF 7

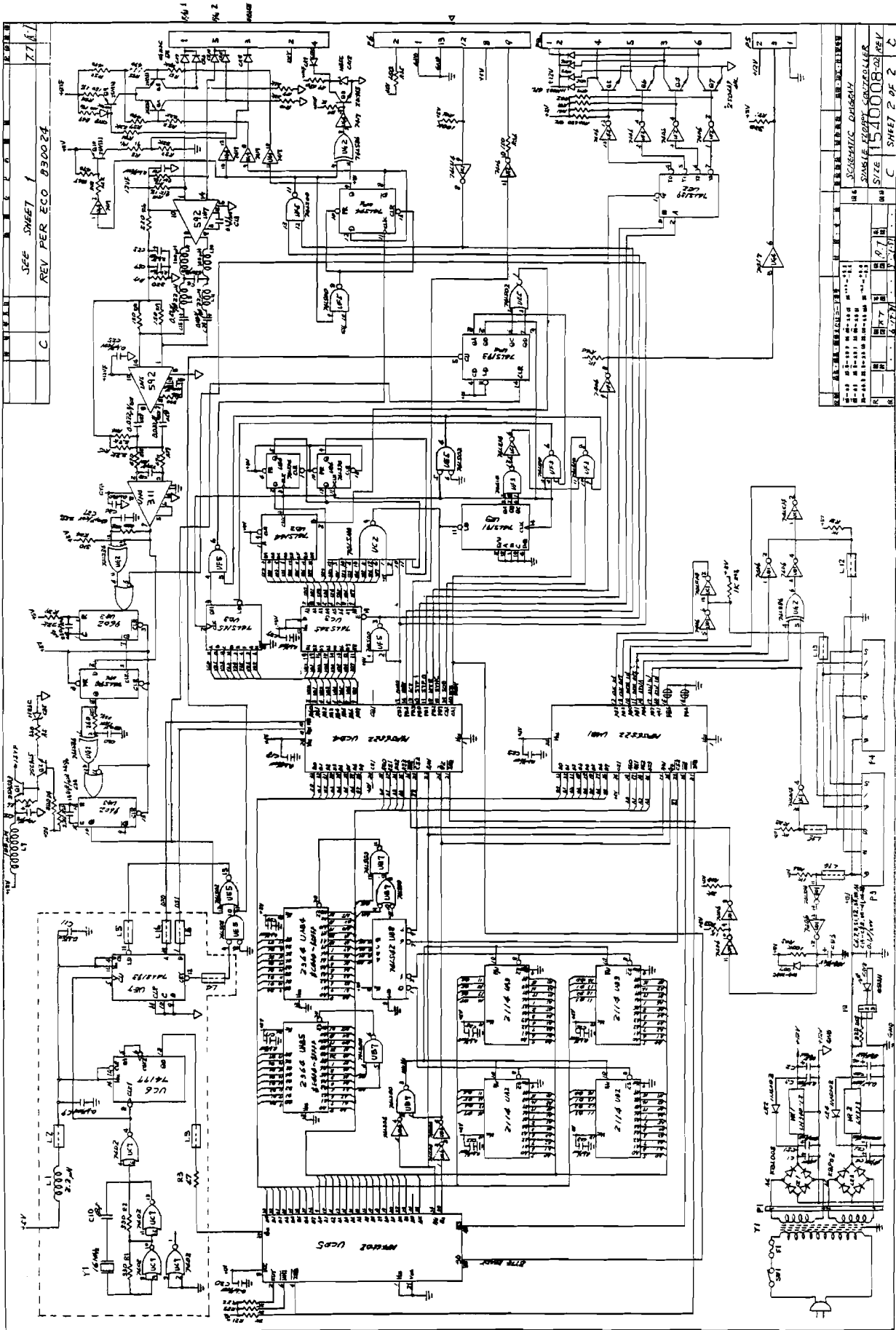

SEE SHEET 1  
REV PER ECD B30024  
C  
77

SCHEMATIC DIAGRAM  
SIZE 54000-02 REV C  
SHEET 2 OF 2  
DATE 4.27.71  
REV 1

PART NO.	DESCRIPTION
1540002-01	POWER SUPPLY ASSY VIC-1540 UL
-06	VIC-1541 UL

REV	DATE	DESCRIPTION	BY
A	8/26/91	PRODUCTION RELEASE	ST
B		CHANGED FILTER POWER CONNECTOR FOR CSA (ITEM 24 WAS ITEM 23)	T.T. ST
C	8/24/92	CHANGED FILTER POWER CONNECTOR FOR FLC (ITEM 25 WAS ITEM 23)	T.T. ST
D	4/22/92	CHANGED ACCESSORY OF TRANSFORMER	T.T. ST
E	8/13/92	CHANGED SCREW TO M3-6 FROM M3-8. ADDED DASH 06 THRU 10 AND ITEM 21.	T.T. ST
F	12/7/92	ADDED ITEM 8, 9 AND 63. ADDED SHEET 5 OF 5.	T.T. ST
G	2/8/93	REVISED PER ECO 830060	ST
H	3/5/93	REVISED PER ECO 830101	ST

4. NO CHANGE QTY FOR ITEM 54 IF USED ITEM 6 OR 7.
  3. USE ONLY WHEN USED ITEM B OR 9.
  2. IF ITEM 8 OR 9 ARE USED THEN QTY FOR ITEM 54 WILL CHANGE FROM 7 TO 9 PCS AND USED WITH ITEM 63.
  1. SHEET 4 & 5 OF 5 ARE D-SIZE ASSY DWG.
- NOTES.

36

c b m ENGINEERING OSAKA JAPAN	TITLE	DRAWN BY:	DATE	DATE	SIZE	1540002-	SHEET 1 OF 5
	POWER SUPPLY ASSY VIC-1540	Y. INABE	7/12/91	1/1	B		
		CHKD		APPR			

QUANTITY REQD PER PART/DASH NO.										QTY	S. D.	PART NUMBER	DESCRIPTION	REF. DES	REMO	NOTES
10	09	08	07	06	05	04	03	02	01							
										S	1	D 1540012	POWER CHASSIS			SUBSTITUTE FOR ITEM 2, SEE NOTE 2
										I	2	D 251153	POWER CHASSIS			SEE NOTE 3
											3					
											4	B/D 1540001 -01	PCB ASSY (FCC) UL			
											5	B/D 1540001 -02	PCB ASSY			
										S	6	B/D 1540001 -03	PCB ASSY (FCC) UL			SUBSTITUTE FOR ITEM 6
											7	B/D 1540001 -04	PCB ASSY			SUBSTITUTE FOR ITEM 9
										I	8	B 1540048 -01	PCB ASSY (FCC) UL			USED LOGIC ARRAY
											9	B 1540048 -02	PCB ASSY			USED LOGIC ARRAY
											10					
											11					
										S	12	B 325519 -01	FLOPPY DISK (BLACK)			SUBSTITUTE FOR ITEM 13
										I	13	B 325519 -02	FLOPPY DISK (BROWN)			
										I	14	B 903614 -01	FUSE HOLDER FH 032			
											15					
											16	B 903615 -01	FUSE HOLDER FH 033			
											17					
											18					
										I	19	B 904509 -01	SWITCH, ROCKER	S W I		
											20					
										S	21	B 325552 -01	FILTER POWER CONNECTOR			SUBSTITUTE FOR ITEM 23 (TOKIN)
											22					SUBSTITUTE FOR ITEM 23
											23					
											24					SUBSTITUTE FOR ITEM 23 (HAWAI PA-126)
										I	25	B 903467 -03	FILTER POWER CONNECTOR			
											26					
										I	27	B 903555 -20	FUSE, SLO BLO 250V 1.0A			5.2" x 20mm 6.3" x 30mm
											28					
										I	29	C 1540009 -01	POWER TRANSFORMER UL JPN 120/100V	T 1		
										S	30	C 1540009 -02	POWER TRANSFORMER C/S/A	T 1		
											31					
											32					
										4	33	B 325548 -04	SCREW PAN HEAD WITH SPRING WASHER MS-10			TO BE ATTACHED WITH X-FORMER
											34					
											35					
											36					

37

c b m ENGINEERING  
OSAKA JAPAN

TITLE: POWER SUPPLY ASSY V.C.1540

DRAWN BY: E. HIRAKAWA  
CHKD: K. ITO

DATE: 11/2/81  
8/2/81

APPR:

DATE: 1/1  
1/1

SIZE: B

1540002-

SHEET 2 OF 5



REVISIONS				
LTR	ZONE	DESCRIPTION	DATE	APPROVED
		SEE SHEET 1	8/21/68	C.T

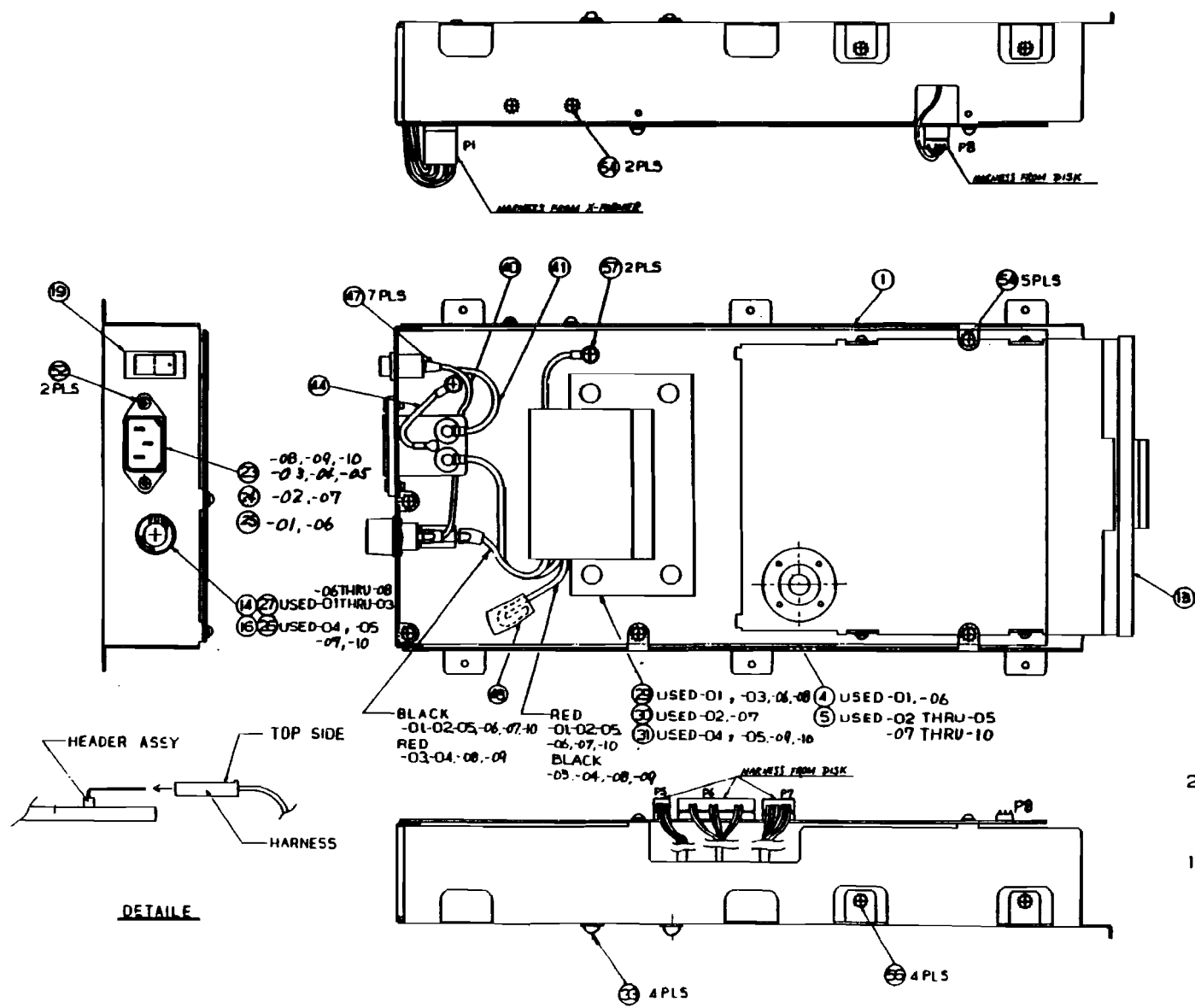

2. ALL LEADS WILL HAVE A MINIMUM OF ONE WRAP AROUND TERMINALS PRIOR TO SOLDERING.
1. ALL OF HARNESS EXCEPT P1 SHOULD BE CONNECTED TO EACH HEADER ASSEY (SEE DETAIL).

Y. INGLE	COMMODORE
POWER SUPPLY ASSY	1540002
1X-54	